

Installation Instructions

WARNING: Unplug scroll saw before installation!

Use your scroll saw owner's manual as a guide in addition to these instructions to retrofit your saw with the Scroll Saw Blade Holder Conversion Kit.

(Not for use on Craftsman Model No. 113.236180)

FOR USE WITH PLAIN END BLADES:

Upper Arm Blade Holder Installation

The upper blade holder assembly has been factory set to accept all plain end blades (skip tooth, reverse tooth, and spiral).

Note: The socket head cap screw should be on your left when using the machine to ease plain end blade installation and removal.

1. Remove the 8-32 x 3/8" socket head cap screw (SHCS), the #8 external lockwasher and the upper blade holder from the upper arm of your saw with the 9/64" hex wrench provided. Save these parts for possible future use.

2. Attach the upper blade holder assembly with the 8-32 x 3/8" long socket head cap screw and M4 single coil lockwasher.

Lower Arm Blade Holder Installation

1. Remove the 8-32 x 3/8" SHCS, the #8 external lockwasher and the lower blade holder from the lower arm with the 9/64" hex wrench.

2. Attach the new lower pin end blade holder (chrome bracket) to the lower arm using the same 8-32 x 3/8" long SHCS and #8 external lockwasher.

Plain End Blade Alignment and Installation

1. Using the black lower plain end blade holder clamp and fixture block provided, put the clamp into the fixture block flat side down, socket head cap screw facing up and the pointed end toward the grooved slot as shown in Fig. 2.

2. Place a plain end blade into the grooved slot with the teeth oriented as illustrated in Figure 2.

Note: Reversed teeth on reverse tooth blades must be placed at this end to cut properly. (See Fig. 2a)

3. Slide the end of the blade into the black lower blade holder and tighten the exposed 8-32 x 3/8" SHCS with 3mm hex wrench. The blade is now properly aligned!

Fig. 1 Plain End Blade Assembly

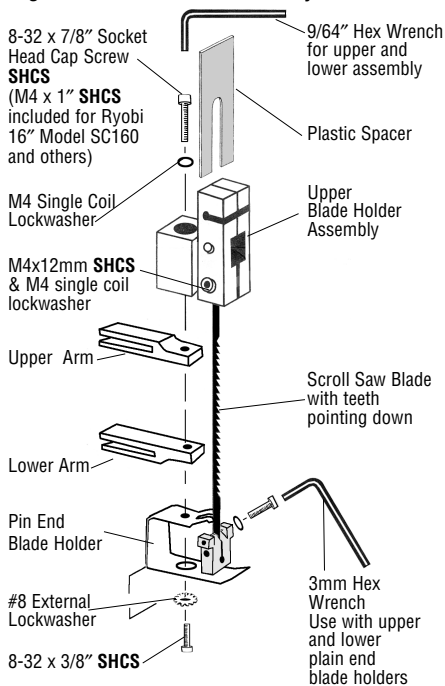
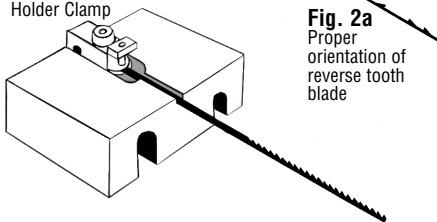

Fig. 2 Fixture Block

Use with Lower Blade Holder Clamp



- Loosen tension by turning knob at the rear of saw.
- Thread the blade with the black lower plain end blade holder attached through underside of the table opening.
- Attach the top plain end first. Place the plastic spacer behind the upper clamps as shown in Fig. 1 (on reverse) and loosen the **SHCS** to slightly separate upper blade holder clamps.
- Hold the blade with your right hand and the 3mm hex wrench in your left hand, place the upper plain end of the blade between the clamps, directly under the **SHCS** of the upper blade holder assembly. Tighten the M4 x 12mm long **SHCS** with 3mm wrench.
- Remove plastic spacer and save for repeated use.
- Install the double pin portion of black plain end blade holder through slot and into the pin recess of the pin end blade holder (chrome bracket).
- Tension knob as required.

FOR USE WITH PIN END BLADES:

Upper Arm Blade Holder Installation

Follow the instructions for "Upper Arm Blade Holder Installation" on reverse and then proceed as follows:

- Using the smaller hex wrench provided (3mm), unscrew the M4 x 12mm long **SHCS** to separate the blade clamps from the center pin.
- Turn the clamps over so that the slot to accept the pin of the blade is at the bottom, facing the operator. Fix each clamp half onto the center pin. Reinsert the M4 x 12mm long **SHCS** and M4 single coil lockwasher and fasten the clamps together.

Lower Arm Blade Holder Installation

Follow the instructions for "Lower Arm Blade Holder Installation" on reverse and then proceed as follows:

- Loosen tension by turning knob at rear of saw.
- Attach the upper pin end of the blade into the slot and pin recess of the upper blade holder assembly. The lower pin end of the blade should go through the table opening.
- Fit the bottom pin end of the blade into the slot and pin recess on lower pin end blade holder (chrome bracket).
- Tension knob as required.

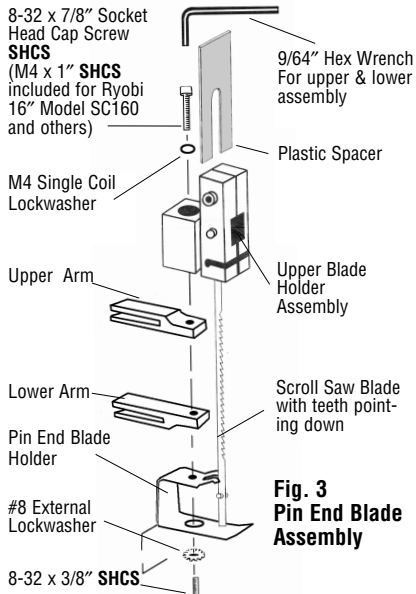

**Fig. 3
Pin End Blade
Assembly**

Making Internal Cuts

Unclamp the upper portion of the blade and pull it through the workpiece and table opening. Reinsert the blade through the table and pre-drilled hole (3/32" dia.) in the workpiece and re-install the blade following the procedures above.

Attaching Scroll Saw Blade Fixture Block (Optional):

The scroll saw blade fixture block can be attached to your saw or table. The top of the fixture should not rise above the table surface or it will interfere with the workpiece to be cut.

- Hold the fixture tightly against the flange of the left or right side of the table (use a "C" clamp if available) and mark hole location with center punch, small drill, or other marking device.
- Using a 7/32" machinist drill, carefully drill the two holes through the flange of base using intermittent pressure.
- Place the #12-24 x 1" screws through the holes and attach the #12 x 24 hex nuts on the opposite side of the flange or base.
- Place the fixture on top of the screw's threads and tighten to secure the fixture against the flange or base.